

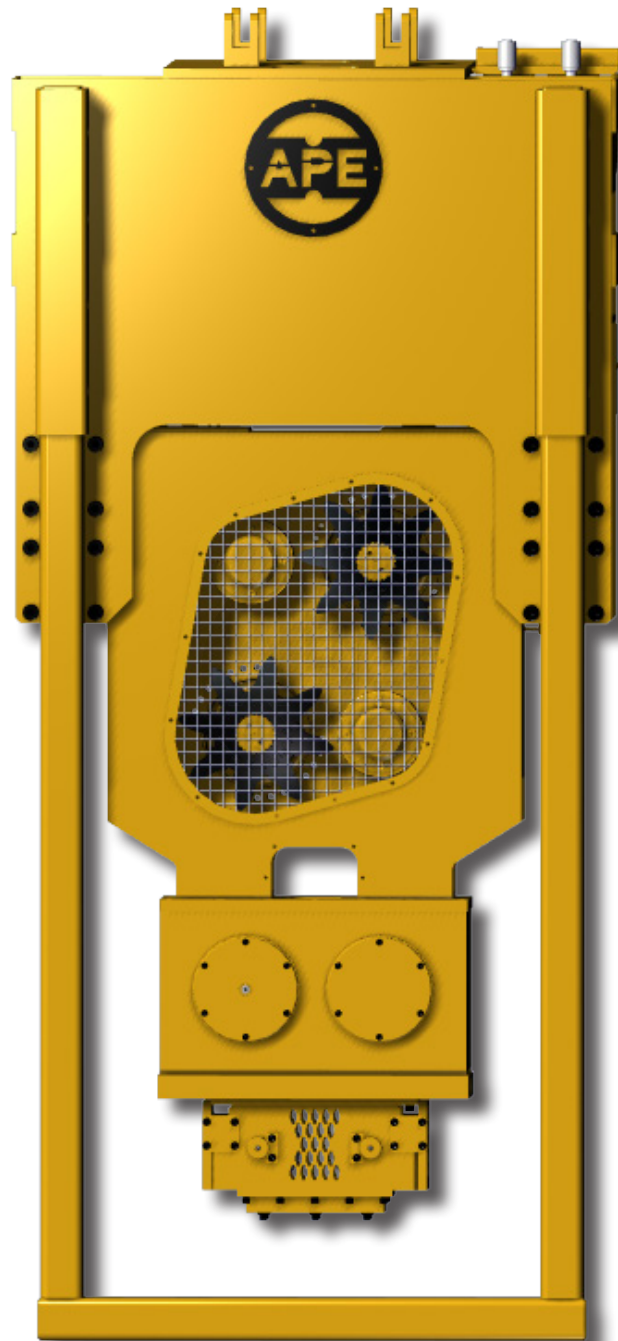

APE WICK DRAIN OWNER'S MANUAL

DEEP FOUNDATION
SOLUTIONS



800-248-8498

WWW.AMERICANPILEDIVING.COM

MODEL 100 WICK DRAIN

Copyright © 2021 American Pilediving Equipment Inc. All Rights Reserved

Copyright © 2021 American Piledriving Equipment Inc.

*All rights reserved, No part of this publication may be reproduced, distributed, or transmitted in any form of by any means, including photocopying, recording, or other electronic or mechanical methods, without prior written permission of the publisher. For permission requests, write to the publisher, addressed “**Attention: American Piledriving Equipment Manual Division**” at the address below.*

AMERICAN PILEDIVING EQUIPMENT, INC.

7032 S. 196th Street

Kent, Washington 98032

Office: 253-872-0141

Toll Free: 800-248-8498

Fax: 253-872-8710

APE_Manuals@americanpiledriving.com

Quick Reference Guide

This Quick Reference Guide will assist you in finding the information you're looking for.

GENERAL INFORMATION

MAINTENANCE & TROUBLESHOOTING

REPLACEMENT PARTS

REFERENCE / NOTES

A Table of Contents is included after the Foreword.

Description:
100 WICK DRAIN

Page 1





WARRANTY INFORMATION



American Piledriving Equipment, Inc. (APE) warrants new products sold by it to be free from defects in material or workmanship for a period of one (1) years after the date of delivery to the first user and subject to the following conditions:

- APE's obligation and liability under this WARRANTY is expressly limited to repairing or replacing, at APE's option, any parts which appear to APE upon inspection to have been defective in material or workmanship. Such parts shall be provided at no cost to the user, at the business establishment of APE or the authorized APE distributor of the product during regular working hours.
- This WARRANTY shall not apply to component parts or accessories of products not manufactured by APE, and which carry the warranty of the manufacturer thereof, or to normal maintenance (such as engine tune-up) or normal maintenance parts (such as filters).
- Replacement or repair parts installed in the product covered by this WARRANTY are warranted only for the remainder of the warranty as if such parts were original components of said product.
- APE makes no other warranty, expressed or implied, and makes no warranty of merchantability of fitness for any particular purpose.
- APE's obligations under this WARRANTY shall not include any transportation charges, costs of installation, duty, taxes or any other charges whatsoever, or any liability for direct, indirect, incidental or consequential damage or delay.
- If requested by APE, products or parts for which a warranty claim is made are to be returned, transportation prepaid, to APE.

OIL MUST MEET ISO CLEANLINESS CODE 17/15/11.
OIL THAT DOES NOT MEET CLEANLINESS CODE WILL
VOID THE WARRANTY

ANY IMPROPER USE, INCLUDING OPERATION AFTER DISCOVERY OF DEFECTIVE OR WORN PARTS, OPERATION BEYOND RATED CAPACITY, SUBSTITUTION OF ANY PARTS WHATSOEVER, USE OF PARTS NOT APPROVED BY APE OR ANY ALTERATION OR REPAIR BY OTHERS IN SUCH A MANNER AS, IN APE'S JUDGMENT, AFFECTS THE PRODUCT MATERIALLY AND ADVERSELY, SHALL
VOID THIS WARRANTY.

ANY TYPE OF WELDING ON APE'S EQUIPMENT WILL
VOID THE WARRANTY UNLESS AUTHORIZED IN WRITING BY APE

NO EMPLOYEE AUTHORIZED TO CHANGE THIS WARRANTY IN ANY WAY OR GRANT ANY OTHER WARRANTY UNLESS SUCH CHANGE IS MADE IN WRITING AND SIGNED BY AN OFFICER OF APE, INC.



(These precautions must be followed at all times to ensure personal and equipment safety.)



DANGER indicates a hazardous situation which, if not avoided, will result in death or serious injury.



WARNING indicates a hazardous situation which, if not avoided, could result in death or serious injury.



CAUTION indicates a hazardous situation where injury could occur but is unlikely to be serious or lead to death.



NOTICE indicates information that may help or guide you in the operation or service of the equipment.

DISCLAIMER

This unit was tested and flushed before leaving our facility. In order to help provide years of trouble free usage, please review the following documentation and make sure to clean and flush the field piping before connecting it to the power unit.

Refer to schematic diagrams and the BOM (Bill of Materials) for component part specifications and recommended spare parts.

When calling APE (American Piledriving Equipment), always inform them of the supplied serial # in order to obtain quicker service.

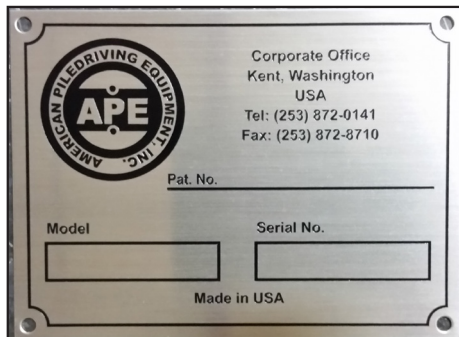

This plate contains numbers key to identifying the unit. This information is important when contacting APE for replacement parts or repair instructions.



READ THIS MANUAL THOROUGHLY BEFORE OPERATING AND / OR WORKING ON THE EQUIPMENT.



A PROPERLY MAINTAINED FIRE EXTINGUISHER, SUITABLE FOR OIL FIRES, MUST BE KEPT IN THE IMMEDIATE VICINITY OF OPERATIONS.



KEEP HANDS, FEET, AND/OR TOOLS WELL CLEAR OF SUPPRESSOR ELASTOMERS.



DO NOT ATTEMPT TO LIFT OR WALK WITH PILES EXCEEDING 10 TONS WEIGHT.

(These precautions must be followed at all times to ensure personal and equipment safety.)

NOTICE

**CHECK THE ENTIRE UNIT PRIOR TO AND DURING SET-UP
EACH DAY OR AT THE BEGINNING OF EACH SHIFT**

Prior to starting the unit or at the beginning of each shift, check the following:

- Visually inspect all bolts, nuts and screws.
- Visually inspect all suppressor elastomers.
- Tighten bolts holding gripping jaws to the hydraulic clamp.
- Check the oil level in the vibration case and add oil if required. The oil level should be in the middle of the sight glass. Change oil if it is milky or contaminated.
- *** DO NOT OVERFILL.**
- Visually inspect all hydraulic fittings for leaks. If a leak is found or suspected, shutdown the power unit. If a fitting appears to be damaged replace it with a new fitting.
- Check the hydraulic motor and hydraulic manifold for leaks.

NOTICE

**IT IS ABSOLUTELY IMPERATIVE THAT NO DIRT OR OTHER IMPURITIES BE PERMITTED
TO CONTAMINATE THE HYDRAULIC FLUID. ANY CONTAMINATION WILL DRASTICALLY
SHORTEN THE LIFE OF THE HIGH-PRESSURE HYDRAULIC SYSTEM.**

VIBRATION LOOSENS BOLTS. CHECK THEM THOROUGHLY.



Do not use the Wick Drain as a lifting device. Can cause property damage, serious injury, or death.

FOREWORD

This manual covers the **100 WICK DRAIN** installation, maintenance and use.

The data provided in this manual gives the necessary information to operate and maintain APE equipment. The listed procedures are to be performed by qualified personnel who have an understanding of the equipment and who follow all safety precautions.

All information given in this manual is current and valid according to the information available at the time of publication. American Piledriving Equipment, Inc. reserves the rights to implement changes without prior notice.

Using this manual:

- Refer to the Table of Contents for the page location of applicable sections.
- All weights and measurements are in English and Metric units.
- Any revisions to this manual will appear on the Revision Record page at the back of this manual.
- Please visit www.americanpiledriving.com for product data sheets and manual.

CALIFORNIA

Proposition 65 Warning

Diesel engine exhaust and some of its constituents are known to the State of California to cause cancer, birth defects, and other reproductive harm.

CALIFORNIA

Proposition 65 Warning

Battery posts, terminals and related accessories contain lead and lead compounds, chemicals known to the state of California to cause cancer, birth defects and reproductive harm. **Wash hands after handling.**

COMMON ABBREVIATIONS AND TERMS

APE : American Piledriving Equipment
Vibro : Vibrator
QD : Quick Disconnect
HCLW : High Collar Lock Washer
SHCS : Socket Head Cap Screw
BOM : Bill of Materials
P.O. : Pilot Operated
Lbs : Pounds
in : Inches
psi : pound per Square Inch
mm : Millimeters

cm : Centimeters
m : Meters
kg : Kilogram
kN : Kilo-newton
Rpm : Revolutions per Minute
Vpm : Vibrations per Minute
cyl : Cylinder
eng : Engine
Mtg : Mounting
Sol : Solenoid
S/N : Serial Number

SERIAL NUMBER LOCATIONS

Vibrator : Above and in between the eccentric covers on both sides of the machine.
Power Unit : On both sides in front of reservoir near the top

TABLE OF CONTENTS

QUICK REFERENCE GUIDE	1
WARRANTY INFORMATION	2
FOREWORD	5
TABLE OF CONTENTS	6
SPECIFICATIONS	7
MODEL 100 WICK DRAIN OVERVIEW	8
WICK DRAIN CHECKLIST PRIOR TO SHIPMENT	10
VIBRATION GEAR BOX	11
UNLOADING	12
SAFETY PRECAUTIONS	12
PREPARATION FOR OPERATION	12
RIGGING OF INSERTER	14
FILLING VIBRATOR PRESSURE HOSE	14
PREPARATION FOR OPERATION	14
HYDRAULIC HOSES CONNECTION	15
ERECTING MAST - LEAD SYSTEMS	16
OPERATION INSTRUCTION	16
DRIVING / EXTRACTING MANDREL	17
RUNNING THE VIBRO (BOTTOM WICK)	17
SHUT DOWN	17
OPERATION INSTRUCTION	17
MAINTENANCE & TROUBLESHOOTING	18
REPLACEMENT PARTS	23
100 WICK DRAIN ASSEMBLY	24
COMMON REPLACEMENT FILTERS	25
BRAKE VALVE SCHEMATICS	29
REPLACEMENT PARTS	29
HYDRAULIC SCHEMATIC	30
REFERENCE / NOTES	32

SPECIFICATIONS

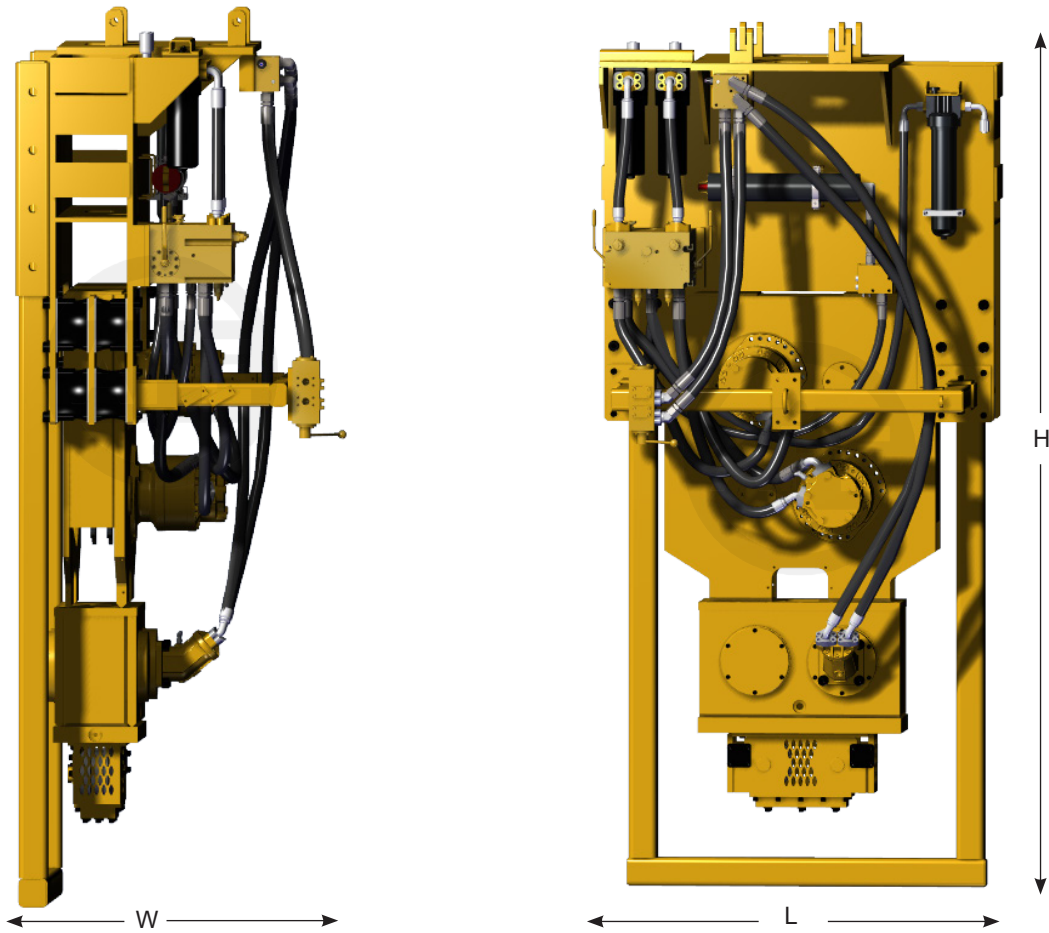

GENERAL INFORMATION

SPECIFICATIONS	DATA
Static (Crowd) Force	279 kN / 28 Us tons
Dynamic Force @ 1,650 vpm	(608 in-lbs) 211 kN / 23.7 US tons
Combined Static / Dynamic Force	458 kN / 51.5 US tons
Operating Frequency	0 - 1,650 vpm
Suspended Weight	3,855kg / 8,500 lbs
Maximum Pressure	380 bars / 5500 psi
Length	217.86 cm / 85.77 in
Width	175.26 cm / 68.99 in
Height	374.01 cm / 147.25 in

Note: Model might not represent current model



GENERAL INFORMATION

MODEL 100 Wick Drain Overview

The APE Model 100 BOTTOM DRIVE WICK INSERTER is a vibratory wick drain inserter. Designed to insert wick drain by forcing a wick threaded mandrel into wet soil while vibrating through tough soil.

The Model 100 Wick operates in a frequency range of 800 to 1,650 vibrations per minute to provide maximum mandrel penetration rates in a wide variety of soils. Produces 23.7 US tons (211 kN) of dynamic force and 28 US tons (279 kN) of static driving force, a combined force of 51.5 US tons (458 kN).

GENERAL INFORMATION

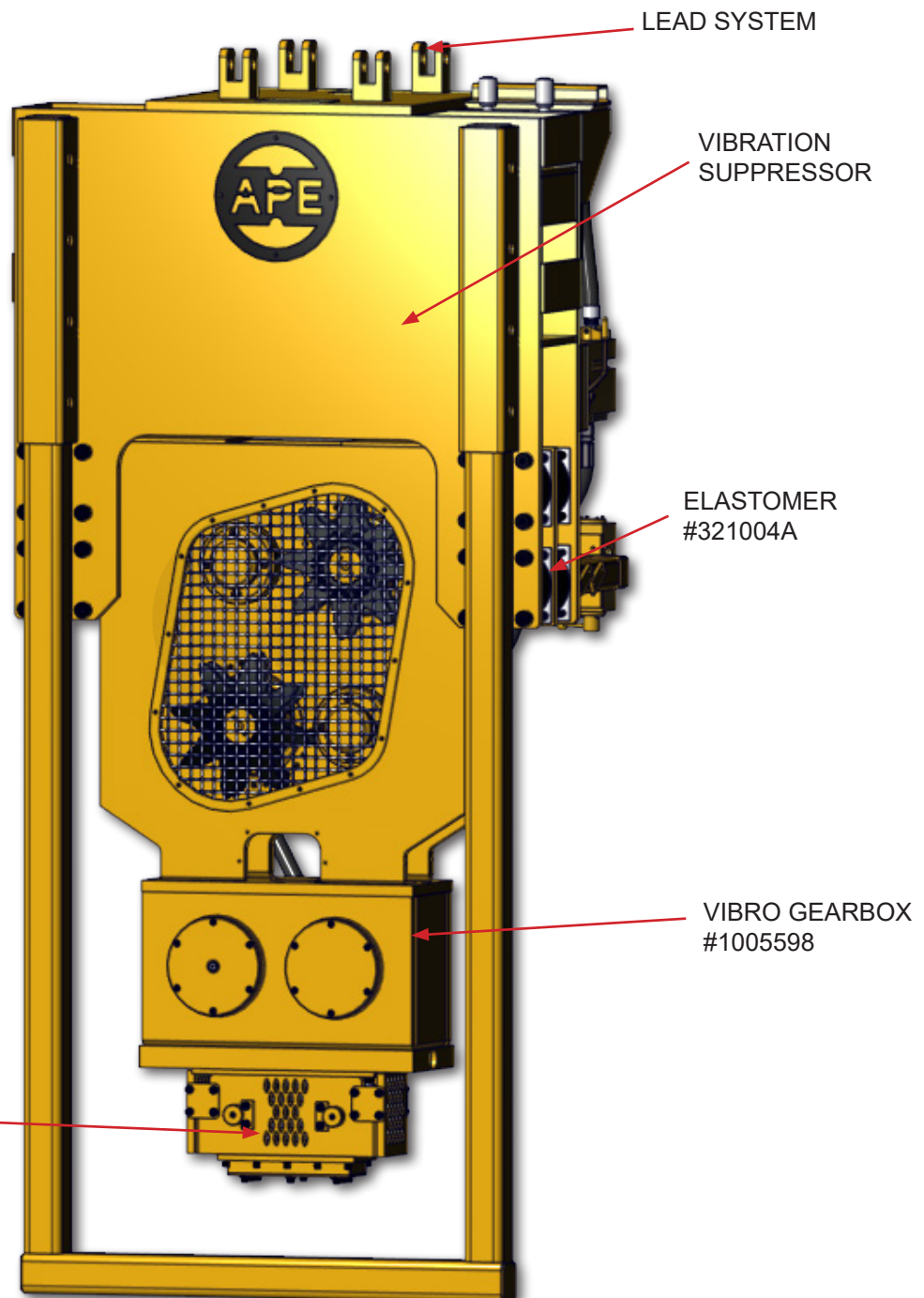

GENERAL INFORMATION

GENERAL INFORMATION

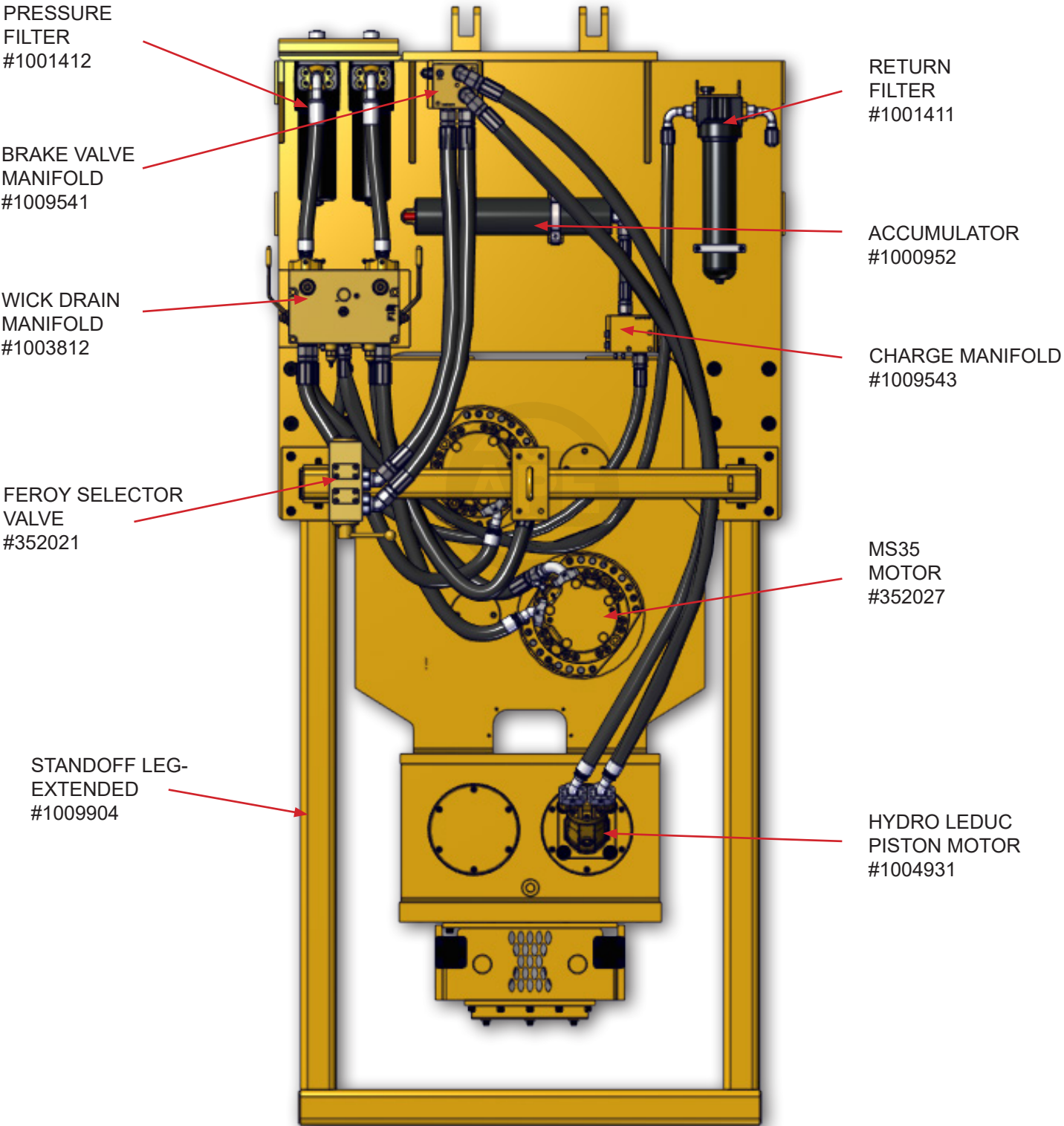

GENERAL INFORMATION

WICK DRAIN CHECKLIST PRIOR TO SHIPMENT

* Items checked with an asterisk should be checked regularly, but not every time the unit is serviced

Checking the suppressor

- Removed all wire rope for insurance reasons
- Checked Shackle pin cotter key and nut
- Checked large elastomers for signs of cracks
- Checked small elastomers for signs of cracks
- Checked all bolts on elastomers
- Removed and checked anti-cavitation valve*
- Inspected pop off safety check valve
- Checked line pull pin and multi-stage pin
- Inspected all suppressor mounting bolts
- Inspected entire suppressor for weld cracks
- Installed safety line pull sticker
- Inspected all hoses and fittings on suppressor
- Inspected all fittings on rifle board top plate
- Checked suppressor loop hoses for wear

Vibro gearbox

- Checked gearbox oil level
- Flushed gearbox with flushing system
- Changed gearbox oil
- Removed and cleaned gearbox oil site gage
- Removed and cleaned magnetic drain plug
- Checked/replaced damaged bearing cover bolts
- Removed, cleaned, and replaced breather valve
- Checked motor bearing cover bolts
- Checked bottom of gearbox- all mounting holes
- Checked entire bottom clamp mounting surface
- Checked hydraulic motor mounting bolts
- Checked motor couplers for leaks
- Checked motor coupler bolts
- Inspected entire gearbox for signs of cracks
- Removed any welding attached by pile crew
- Inspected main bearings visually for wear*
- Inspected motor bearings visually for wear*
-

Vibro test

- Checked and cleaned quick disconnects
- Checked to make sure caps and plugs are there
- Checked all o-rings on QD's
- Put spare o-ring kit in tool box of power unit
- Closed jaws and checked hoses for leaks
- Checked clamp pressure with hoses attached
- Checked pendant light to make sure it works

Test Data:

Free hanging drive pressure: _____

Cycles per minute: _____

Temperature of hydraulic oil at time of test: _____

Tips for the APE service technicians and pile crew:

Please clean the control panel and spray some armor all on it. Prior to the vibro going out on rent it must look like new condition. If the paint appears bad then paint it. If the paint surface is bad then have it sand blasted. Do not allow the hammer to go out looking bad. Any bad hoses should be replaced. The most important thing is the condition of the jaws and the hoses. Both should be new or in new condition. If this unit is going to operate in cold weather then please make sure the proper oils have been used. In cold weather operations we must use a softer o-ring to handle the colder temperatures. Spare parts that should be with the vibro power unit:

- One sight glass with teflon tape already installed and boxed
- One socket wrench for removing and replacing sight glass
- One manual with copy of this check out sheet

GENERAL INFORMATION

VIBRATION GEAR BOX

The vibration gear box contains four eccentric weights which rotate in a vertical plane to create vibration (Dynamic Force). The eccentric weights are driven by a hydraulic motor.

VIBRATION SUPPRESSOR

The vibration suppressor contains 12 rubber elastomers to isolate the vibration case from the leads. The mandrel insert / extract motors are mounted here. A pair of hydraulic motors with a sprocket assembly mounted to the motors force the mandrel into the ground as well as removing the mandrel from the ground. There is a roller assembly that works together with the sprockets keeping the mandrel engaged with the sprockets.

WICK CARRIER

The wick carrier assembly is designed to carry six spools of wick drain. This assembly has capability to hold one spool on the center of the wick tube and five to the side of center of the wick tube. While you line-up the first spool of wick to the wick tube the rest of the carrier can hold the spare spools of wick. When the center spool is close to being empty mechanically join the end of the wick to the beginning of a new spool of wick. When the center spool is empty, remove spool bracket and wick roll tube. Re-install spool bracket, slide the wick spools so that the first spool is in-line with the wick tube and slide the other spool bracket over to keep the remaining wick spools in place. Continue to mechanically joining the end of a spool to the beginning of the next spool and adjusting the spool bracket.

MANDREL GUIDE

The mandrel guide is a set of rollers at the bottom of the vibration case used to maintain position of the mandrel fore and aft as well as right and left. The mandrel is a rectangular steel tube that is used to thread the wick drain into the soil.

LEGS

The legs are to rest upon the ground to stabilize the wick inserter while inserting wick or removing the mandrel. They are adjustable to suit the job site and operators preference of height for best visibility.

LEADER SYSTEM

The leader system is a lattice system used to support and guide the mandrel and wick drain. This system has a trough for the mandrel to run in maintaining it's location in relationship to the wick inserter assembly. A set of lugs and pins connect the leader system together as well as the leader system to the inserter assembly. On top of the leader system is a wick guide bracket that aligns the wick drain that goes to the top of the leader system and over to top of the mandrel.

PREPARATION FOR OPERATION

UNLOADING

When unloading and unpacking the bottom drive wick inserter, use extreme care. For your protection, make a thorough inspection of the unit immediately on delivery. In case of any damage or shortage, notify the transit agent at once and have the delivering carrier make a notation on the freight bill.

SAFETY PRECAUTIONS

Safety is very important and is everyone's responsibility that operates this equipment or services this equipment.

Use the following safety precautions as a general guide to safe operations, when in doubt consult APE before proceeding with any operation that may produce an unsafe result. These safety guidelines do not constitute all possible safety issues that may occur during operation or maintenance.



1. Read this manual thoroughly before operating or working on the equipment.
2. Read and follow any safety instructions in the excavator's operators manual.
3. Only well trained and experienced personnel should attempt to operate or maintain this equipment.
4. Never adjust, lubricate or repair the unit when it is in operation, or lifted above ground level.
5. Never remove, paint over or cover warning or safety labels. If labels become damaged or unreadable, replace immediately.
6. All personnel should wear approved safety clothing, including HARD HATS, SAFETY SHOES, SAFETY GLASSES and HEARING PROTECTION when in the vicinity of this machinery.
7. Do not stand any closer to this equipment than necessary when it is in operation. Parts may loosen and fall. Never stand under operating, or elevated, equipment.
8. When maintaining or repairing the equipment, never substitute parts not supplied, or approved in writing, by APE.
9. Do not weld, or flame cut, on this equipment.
10. Never use or store flammable liquids on or near the engine.
11. Insure that all lifting equipment, including cranes, wire rope, slings, hooks, shackles, etc., are properly sized for the worst case loads anticipated during operations.
12. If there are any questions about the weights, specifications, or performance of the unit, contact APE before handling or operating the equipment.
13. If the equipment is to be used for anything other than inserting plumb wick drains, contact APE before using the unit.
14. Insure that ground vibrations will not damage or collapse adjacent structures or excavations.
15. Remove all tools, parts and electrical cords before starting the unit.
16. When operating in an enclosed area, pipe exhaust fumes outside. Continued breathing of exhaust fumes

PREPARATION FOR OPERATION

SAFETY PRECAUTIONS (CONTINUED)

may be fatal.

17. When servicing batteries, do not smoke or use open flames in the vicinity. Batteries generate explosive gas during charging. There must be proper ventilation when charging batteries.
18. When filling fuel tank, do not smoke or use open flame in the vicinity.
19. If abnormal equipment operation is observed, discontinue use immediately and correct the problem.
20. Do not adjust, or set, hydraulic pressures higher or lower than those specified in this manual.
21. Never operate this equipment with hydraulic hoses that are damaged or “kinked”. Replace damaged hoses immediately.
22. Do not lift, or support, hydraulic hoses with wire rope slings.
23. Do not pull on, or attempt to move equipment, with hydraulic hoses.
24. Do not attempt to locate hydraulic leaks with your hands. High pressure hydraulic leaks can penetrate the skin, causing severe damage, blood poisoning and infection. Do not attempt to repair leaks while the equipment is in operation.
25. Do not attempt to tighten, or loosen, fittings or hoses when the machine is in operation.
26. A properly maintained fire extinguisher, suitable for oil fires, must be kept in the immediate vicinity of equipment operations.
27. When moving or transporting this equipment, insure that the vehicle or vessel is of sufficient capacity to handle the load, and that the equipment is properly tied down.
28. Be sure that all equipment parts are tight, or properly secured, before shipment. Unsecured parts may vibrate loose and fall, during transport, causing injury or property damage.
29. Keep crane boom, mandrel, lead system, wire rope and other equipment at least 15' (5M) from electrical power lines, transformers and other electrical equipment, or at such distance as required by applicable safety codes.
30. Rounded or damaged bolt heads or nuts should be replaced so that proper torque values may be obtained. Proper torque values are necessary to prevent parts on this equipment, leads and crane boom from loosening and falling. Refer to Torque Chart, in this manual, for proper values.
31. Never induce mandrel crowd or extraction force before starting the unit in vibration. Always start both driving and extraction of mandrel insertion / extraction circuit in neutral.
32. Keep hands away from mandrel sprocket assemblies.
33. Keep hands away from vibrator suppressor during operation. Clearances may change causing pinch points.
34. When driving “batter” wick drain insure that the lead system, and crane boom, have sufficient bending strength to handle the worst case load. Consult APE.

NOTICE

PREPARATION FOR OPERATION

RIGGING OF INSERTER

A mast system is designed to mount to the base rig that the Bottom Drive Wick Inserter is mounted to that also guides the Mandrel with the wick. The following instructions provide guidelines for the assembling.

An adapter has been designed for the entire assembly for the original project to a certain excavator.

1. With Mast in horizontal position bolt the lower two wick lead sections to mast.
2. Stand mast vertical.
3. Pin bottom drive wick inserter to wick lead.
4. Lower mast to horizontal.
5. Pin upper sections of wick lead to the lower sections that are bolted to the mast.
6. Supporting and hanging mandrel load into the bottom of bottom drive wick inserter using Roller Guide Asm.
7. With the BV1 motor valve in the "FREE WHEEL" position and the needle valve (NV1) closed all but one turn open.
8. Slowly pull the lever in the extract wick position to allow the bottom motor sprocket to pull the mandrel into the mast.
9. The mandrel will engage into the upper motor sprocket. You can continue to feed the mandrel as is.
10. With BV1 turned to the "RUN" position and the NV1 open all the way feed the remainder of the mandrel.

The pins supplied for the mast are the only pins to be used and installed with supplied fastening hardware.

The mandrel can be loaded in the lengths of delivery and welded together as the end of the mandrel nears the Roller Guide Asm. Another way to load the mandrel is to completely weld the entire length in advance. Either way it is a must to use the Mandrel Template P/N: 352017 to align and properly space the sections.

NOTICE

All rigging of either the inserter must be done in accordance with standard rigging guide lines set forth in ASTM standards; APE does not assume responsibility for incorrect rigging or procedures.

FILLING VIBRATOR PRESSURE HOSE

The vibrator is usually shipped with the vibrator hydraulic hoses full of fluid and the unit may be used immediately. However, if the pressure hose has been removed from the vibrator, the hose should be allowed to fill with hydraulic fluid prior to full speed operation.

- Start and warm up the diesel engine, Hold the vibrator in a vertical position.
- With the engine warmed up and running at 1000 RPM, turn and hold the vibrator switch REVERSE. The hoses will fill in approximately 5 minutes.

NOTICE

WARNING

If vibration begins in the vibrator, stop immediately and recheck hose connections.

PREPARATION FOR OPERATION

HYDRAULIC HOSES CONNECTION

1. Connection of hoses inserter.

- The inserter gear box motor and crowd / extraction motors are connected to the base rig by five hydraulic hoses.

The base rig must be shut down during connection of the hydraulic hoses.

- Clean connection fittings with a lint-free cloth before making connections.
- Make sure that the connectors are fully tightened with wrenches.

Connection of hoses at base rig.

- The vibrator circuit is controlled by the tool circuit.

NOTICE

Use caution when bleeding any hydraulic lines, even low hydraulic pressure can cause injury to personnel.



EXCAVATOR CONNECTION

Contact APE Certified Service Technician for more information

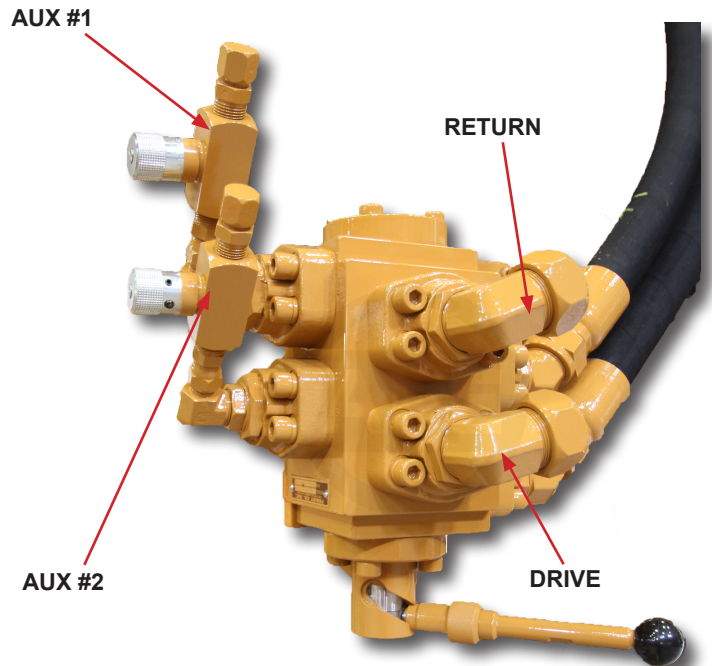
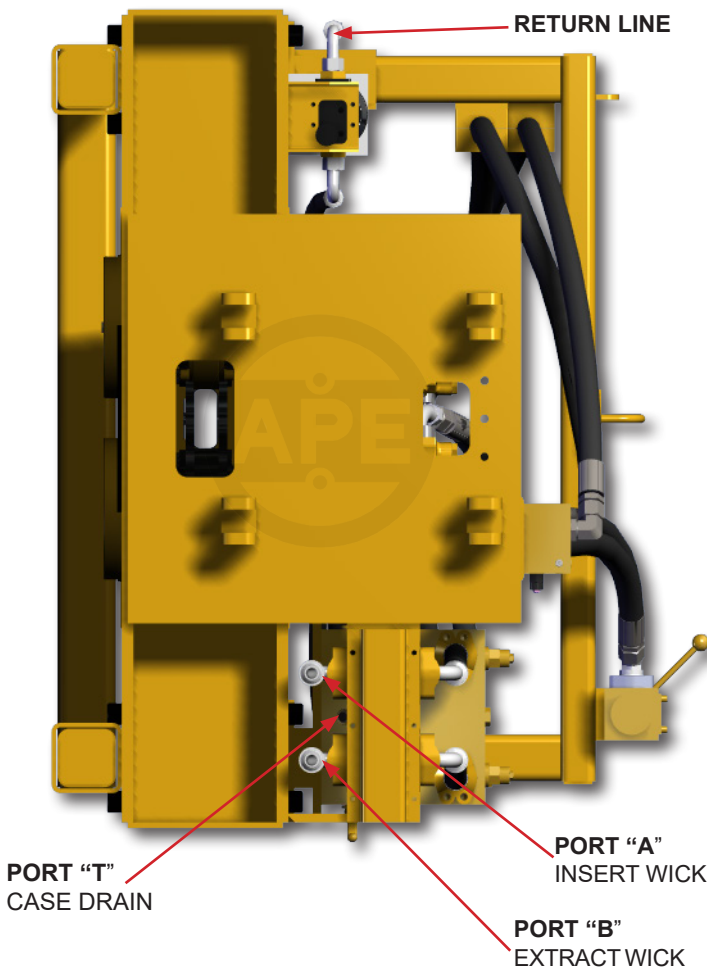

NOTE: AUX #1 & AUX #2 CONTROLS THE MAST ROTATE CYLINDER.

GENERAL INFORMATION

Note: Model might not represent current model

Page 15



OPERATION INSTRUCTION

ERECTING MAST - LEAD SYSTEMS

Raising the Mast:

1. The mast is raised by pushing the "LEADER ERECT" lever, this lever is on the far right and the knob is Black.
2. The mast will rise to about 30 degrees from horizontal and the limit switch will stop movement, an alarm will sound.
3. Pull the "WINCH-MAIN" lever, this lever is the second from the right and the knob is Red.
4. The mast will be hoisted bringing the base rearward until it stops the alarm will stop. This has released the limit switch.
5. Push the "LEADER ERECT" lever until the mast is in full vertical position.



Adjustment of the mast - lead system should only be done when NO mandrel is below the surface of soil.

Lowering the Mast:

1. The mast is lowered by pulling the "LEADER ERECT" lever, this lever is on the far right and the knob is Black.
2. The mast will lower until about 30 degrees from horizontal and the limit switch will stop movement, an alarm will sound.
3. Push the "WINCH-MAIN" lever, this lever is the second from the right and the knob is Red.
4. The mast will be lowered bringing the base forward until it stops the alarm will stop. This has released the limit switch.
5. Pull the "LEADER-ERECT" lever until the mast is completely down resting in the mast cradle. In the case that the operator wants to lower the mast into the cradle slower there is a toggle switch. Pull and hold the toggle switch labeled "SUPER SLOW" all the while pulling the "LEADER-ERECT" lever.

NOTICE

Attention: All fully assembled rig movement is to be done with mast in the full vertical position!

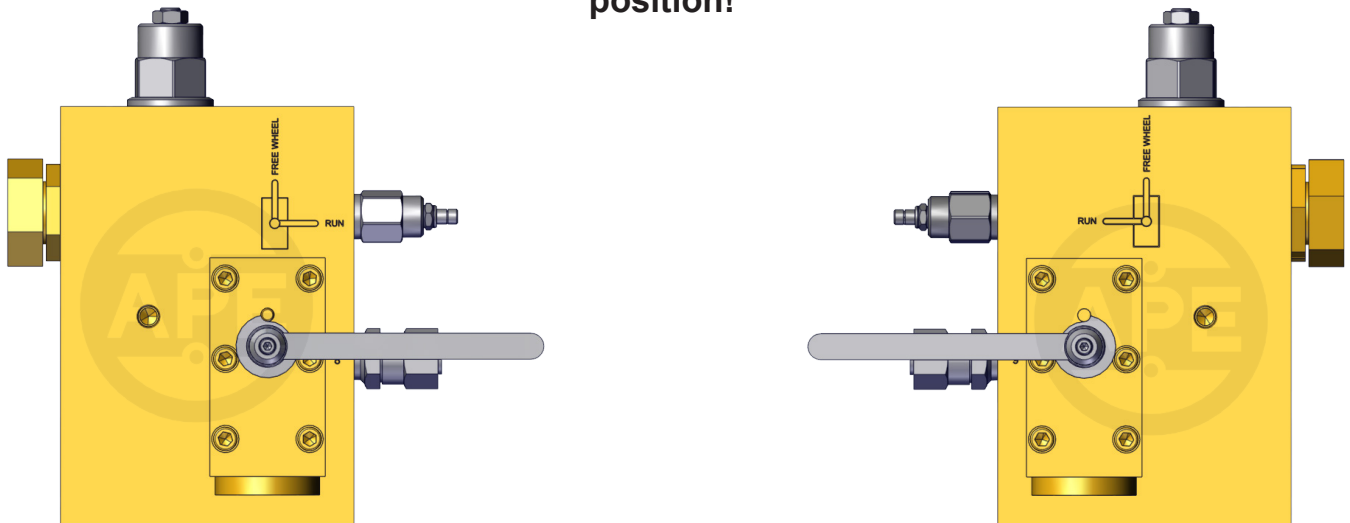

OPERATION INSTRUCTION

DRIVING / EXTRACTING MANDREL

- Pushing the “WINCH-AUX” lever, this lever is the third from the right and is the knob is Blue.
- Pushing and holding the lever a small amount will allow the mandrel to move down slowly. The further the lever is pushed the faster the mandrel will move.
- Returning the lever to the neutral position stops the mandrel.
- Pulling the “WINCH-AUX” lever, this lever is the third from the right and is the knob is Blue.
- Pulling and holding the lever a small amount will allow the mandrel to move up slowly. The further the lever is pushed the faster the mandrel will move.
- There is an indicator at the top of the mandrel. This indicator allows the operator and crew to know how far the mandrel is in the ground by how much is above the bottom drive wick inserter. This indicator is especially useful to determine how much mandrel is left in the ground when extracting the mandrel. The crew and operator must keep in mind that the mandrel will not stop based on the position the mandrel. The mandrel will smash out the top roller if the mandrel is not stopped before this happens.

RUNNING THE VIBRO (BOTTOM WICK)

- When the mandrel slows or stops running into the ground using the mandrel inserting motors the use of the vibros is needed.
- A good indicator that the driving of the mandrel is getting tough the gear case will be pushed up into the suppressor.
- It is recommended that when you see this happen push and hold the “VIBRO” button.
- Within a few seconds the Vibro will begin to vibrate at full speed.
- With Vibro running at full speed continue to run the mandrel.
- If you wait until the mandrel stops release the WINCH AUX lever and push and hold the “VIBRO” button.
- With Vibro running at full speed continue to run the mandrel.
- When the tough soil layer is broken through release the “VIBRO” button while continuing to run the mandrel.

SHUT DOWN

1. Stop the vibration gear box and mandrel drive motors.
2. Allow the diesel engine to run for five minutes at 1500 RPM.
3. Reduce speed to low idle for about thirty seconds.
4. Stop the engine by turning the ENGINE START switch to OFF.

MAINTENANCE & TROUBLESHOOTING

MAINTENANCE CHART

NOTICE

Preventive maintenance includes normal servicing that will keep the wick inserter in peak operating condition and prevent unnecessary trouble from developing. This servicing consists of periodic lubrication and inspection of the moving parts and accessories of the unit.

Lubrication is an essential part of protective maintenance, controlling to a great extent the useful life of the unit. Different lubricants are needed and some components in the unit require more frequent lubrication than others. Therefore, it is important that the instructions regarding types of lubricants and frequency of their applications be closely followed.

To prevent minor irregularities from developing into serious conditions that might involve shut-down and major repair, several other services or inspections are recommended for the same intervals as the periodic lubrications. The purpose of these services or inspections is to assure the uninterrupted operation of the unit.

Thoroughly clean all lubrication fittings, caps, filler and level plugs and their surrounding surfaces before servicing. Prevent dirt from entering with lubricants and coolants. The intervals given in the schedule are based on normal operation. Perform these services, inspections, etc., more often as needed for operation under abnormal or severe conditions.

DAILY	WEEKLY	70 HOURS
<ul style="list-style-type: none"> • Check operators report. • Check oil level in the gearbox and bring to correct level. • Inspect bolts, nuts, and screws for tightness. • Inspect elastomers for cracks. • Inspect fittings, hoses, and manifolds for leaks. 	<ul style="list-style-type: none"> • Inspect hydraulic hoses and fittings for fraying and leaks. Replace any hoses with broken threads. • Bleed air from the hydraulic lines as described in the previous chapter. • Inspect gearbox magnetic drain plug for metal flakes. If flakes are found see Troubleshooting chart. 	<ul style="list-style-type: none"> • Change gearbox oil. • Clean gearbox breather and pop-off valves. • Cycle oil into the hydraulic clamps as described later in this chapter.
250 HOURS OR 6 MONTHS	1500 HOURS OR 1 YEAR	6000 HOURS OR 3 YEARS
<ul style="list-style-type: none"> • Inspect eccentric bearings. 	<ul style="list-style-type: none"> • Check torque on gearbox, suppressor, and clamp attachment mounting bolts. • Inspect hydraulic motors for leaks, wear, and proper operation. • Replace eccentric bearings. 	<ul style="list-style-type: none"> • Inspect, replace eccentrics, elastomers, and hydraulic motors if necessary.

MAINTENANCE & TROUBLESHOOTING

SEVERE CONDITIONS

The servicing intervals are specified on normal operation conditions. Operation under severe conditions require shorter service intervals.

- When the average outside temperature is above 80 F (26 C) or below -10 F (-23 C), reduce service time intervals by one-half.
- When operating in the presence of dust or sand, reduce service time intervals by one-half.
- When operating in air with high salt or moisture the service intervals do not need to be changed. However the unit should be inspected weekly to determine if additional servicing is required.
- When operating in excess of twelve hours per day, reduce service time intervals by one-half of those specified.

VIBRATORY GEARBOX

The oil level is easily read through the sight glass located at the lower center of the vibratory gearbox on the motor side. Lubricating oil may be added when necessary, through the hole in the vibration case top plate after removing the 1" SAE O-ring plug. To drain the case, remove the 1" pipe plug at the end of the base plate. Tilt the case for complete drainage.

The preferred lubricating oil for APE vibro gearbox is high molly oil. The recommended oil by APE is Schaeffer 268.

OIL RECOMMENDATIONS

The gearbox lubricant installed by APE during manufacturing is Schaefer 268. If it is unavailable an alternative oil may be used when changing lubricants. Test and change the gearbox oil at smaller intervals if Schaefer 268 is not being used. The gearbox capacity is 1.5 gal, fill until you reach the half line mark on the sight glass.

Second Preference Group

Mobil	SHC-634
Boron	Gearep 140
Chevron	Gear Comp. NL460
Citgo	Premium MP 85W-140
Citgo	Standard MP 85W-140
Gulf	Lub 85W-140
Phillips	MP 85W-140
Shell	Omala 460
Sun	Sunep 1110

Third Preference Group

Amoco	Perma Gear EP140
Arco	Pennant NL 460
Conoco	EP 460
Exxon	Spartan EP 460
Phillips	AP 140
Texaco	Meropa 460
Union	MP 85W-140
Valvoline	Gear Lub 85W-140

Hydraulic Oil Cleanliness

When adding or changing hydraulic fluid, APE uses only Biodegradable Envirollogic 146 hydraulic fluid. Consult your local oil supplier for recommendations on mixing hydraulic oils. See the warranty document at the beginning of this manual concerning fluid cleanliness, and Understanding ISO Codes at the rear of this manual.

NOTICE

**NEW HYDRAULIC FLUID IS NOT CLEAN OIL!
OIL MUST MEET ISO CLEANLINESS CODE 17/15/11**

MAINTENANCE & TROUBLESHOOTING

STORAGE

During short-term storage of a Vibro, the following should be taken into consideration:

- Cover any pressure openings and open threaded holes with suitable caps.
- Protect the unpainted surfaces from dirt and moisture.
- The vibro should not be stored in an area with substances that have an aggressive corrosive nature; solvents, acids, alkalies and/or salts.

For long-term storage (over 9 months), the following additional actions are recommended:

- Damages to surface paint must be repaired before item is stored.
- Protect the unpainted surfaces with suitable anti-corrosion treatment such as CRC SP-350, CorrosionX corrosion inhibitor, or WD-40 Long Term Corrosion Inhibitor.
- Fill the power unit completely with hydraulic fluid.

If these instructions are followed to the letter, the vibro may be stored for approximately 2-years. However, as storage conditions do have a significant effect, all suggested time frames should be considered as guide values only.

READING THE GEARBOX OIL LEVEL

The gearbox oil is a useful indicator of the health of the unit. Check the Troubleshooting chart if gearbox is overfilled, has discolored oil, or the oil contains metal flakes.

The oil level may be read from a sight-glass halfway up the vibro gearbox. Ideally the oil will fill midway up the sight-glass when the vibro is upright. If the level cannot be read remove the sight-glass and clean the window with ether.

NOTICE

IF YOU CANNOT READ THE GEARBOX SIGHT-GLASS DO NOT ASSUME IT IS FILLED. YOU MUST READ THE LEVEL TO RUN THE VIBRO.

Graphic of the sight-glass at ideal fill level.

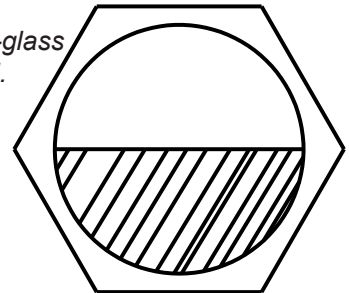

CHANGING GEARBOX OIL

Gearbox oil can be added through a hole in the gearbox top plate. Remove the SAE plug to add oil.

To drain the gearbox, remove the pipe plug beside the gearbox sight-glass and tilt the vibro until the oil drains out.

Do not overfill the gearbox. Gearbox oil is viscous when cold. Add one gallon, allow the oil to spread out, then fill the remainder slowly while watching the sight glass.

When replacing either of the pipe plugs, add sealing tape to make sure oil and containments cannot enter or leave the gearbox.

MAINTENANCE & TROUBLESHOOTING

CHECKING BEARINGS AND ECCENTRICS

Periodic maintenance and some vibro symptoms require the gearbox bearings to be inspected. The results of this inspection may indicate that the eccentrics require replacement.

During this check make sure no dust, dirt, or other contaminants can enter the gearbox.

If this procedure is being followed as part of regular maintenance only one cover needs to be removed and examined. If a problem is suspected all covers should be removed and inspected.

1. Remove one gearbox bearing cover.
2. Clean the bearing face. Examine both the bearing face and the interior of the bearing cover for wear or scorch marks.
3. Check the stamping on the outer ring of the bearing. There should be letters etched top.
 - If the lettering is not on top, tap the bearing with a rubber mallet to check if it is loose. If it is loose, replace it and check the eccentrics.
4. Inspect all visible components for chipping, pitting, corrosion, or deformation.
5. If no damage is found, apply lube to the bearing cover o-ring. Re-seat it, then attach the bearing cover to the gearbox with loctited bolts.

It is often difficult to determine if the eccentrics are damaged. In general, damage to a bearing requires the replacement of an eccentric. To check the eccentrics:

1. Unbolt and remove the suppressor and gearbox top plate.
2. Inspect eccentrics for chipping, pitting, corrosion, or deformation.
3. Replace damaged eccentrics and bearings, if necessary.
4. Apply fresh lube to o-ring cord before sealing gearbox.



*Etched words of manufacture location example: "USA" should be top center of bearings. If lettering is not on top, tap on the bearing with a rubber mallet to check if it is loose.
Note: not all bearings are made in USA.*



Metal flakes have pooled at the bottom of this bearing. It needs to be replaced.



Damaged eccentric bearing in need of immediate replacement.



ECCENTRICS MAY SWING UNEXPECTEDLY AND ARE HEAVY. THE INTERIOR OF THE GEARBOX IS A MAJOR PINCH AND CRUSH HAZARD WHEN OPEN.

Hydraulic motor on gearbox.

Page 21



800-248-8498
WWW.AMERICANPILEDIVING.COM

100 WICK DRAIN

Copyright © 2021 American Piledriving Equipment Inc. All Rights Reserved

MAINTENANCE & TROUBLESHOOTING

TROUBLESHOOTING CHART

SYMPTOM	POSSIBLE CAUSE	SOLUTION
<u>Oil blowing out between gearbox and hydraulic motor</u>	<ol style="list-style-type: none"> 1. Blocked case drain. 2. Breather plugged or damaged. 3. O-rings not sealing properly. 	<ol style="list-style-type: none"> 1. Ensure case drain hose is attached and not kinked. 2. Remove and clean breather, replacing if damaged. 3. Verify o-ring seal and cleanliness between gearbox and motor.
<u>Vibro gearbox overheating at the bearing covers</u>	<ol style="list-style-type: none"> 1. Vibro is being run too hard. 2. There is too much or too little oil in gearbox. 3. Gearbox oil is damaged. 	<ol style="list-style-type: none"> 1. Check that the unit is penetrating at least 1 inch of soil for every 30 seconds of operation. Allow the vibro to cool down between sessions of hard operation. 2. Set the gearbox upright and level and check the sight glass. If the oil level is too high remove the sight glass and allow some to drain. If it is too low replace missing oil. 3. Check oil quality in sight gauge and drainage plug. For oil that is black, milky, or contains large metal flakes see the next symptom on this chart.
<u>The gearbox oil is discolored or contains contaminants</u>	<ol style="list-style-type: none"> 1. Gearbox oil has a dark or milky appearance from water, hydraulic oil, or dirt. 2. Damaged bearings or eccentrics are leaving metal flakes or brass chunks. 	<ol style="list-style-type: none"> 1. Check all seals, especially those near the hydraulic motor, hoses, and the gearbox exterior for damage, breaches, or faulty o-rings. 2. Perform the check bearings and eccentrics procedure. If damage is found replace the components and gearbox oil.
<u>Gearbox is filling with oil</u>	Hydraulic oil is entering the gearbox through a bad motor seal.	Remove the hydraulic motor and check for damage to the o-ring or gearbox.
<u>Vibro won't come up to normal operating speed</u>	<ol style="list-style-type: none"> 1. Power unit at low RPM. 2. Hoses are damaged or kinked. 3. Defective or damaged hydraulic motor. 4. Power unit pumps need repaired. 	<ol style="list-style-type: none"> 1. Raise the Power unit engine RPM. 2. Check all hose connections and fix any loose or kinked lines. 3. Perform the Checking Hydraulic Motors procedure. Replace a motor that shows damage. 4. Contact a Qualified Service Technician to service or replace the power unit pump.
<u>An attachment bolt broke</u>	1. Bolts didn't fully seat or are overstressed.	1. Replace all clamp bolts with special attention paid to cleaning all surfaces. Check working loads to ensure they're within acceptable levels.
<u>Vibro won't start when DRIVE button is engaged</u>	<ol style="list-style-type: none"> 1. The Vibro won't drive while the clamp is open. 2. Hoses not connected properly. 3. The hydraulic motor is damaged. 4. Gearbox seized up. 	<ol style="list-style-type: none"> 1. Make sure the clamps are fully closed and the clamp light is on at the joystick. 2. Check hose connections at the Vibro Pigtails, Qd, and Power unit. 3. Follow Checking Hydraulic Motors procedure. 4. Inspect the gearbox, bearings, and eccentrics. If there is damage found consult APE for repair and/or replacement.

MAINTENANCE & TROUBLESHOOTING



REPLACEMENT PARTS

ORDERING REPLACEMENT PARTS

Unit Information

Provide the serial and model number of the unit when contacting APE for replacement parts. This information can be found on a tag like the one on this page. Confirm all orders in writing to avoid duplicating shipments.

Original and Modified Equipment

The previous equipment breakdowns apply only to equipment originally furnished with the unit. Any equipment that has been changed or upgraded won't be accurate to these schematics.

Shipment

If the shipment recipient and method of shipment isn't stated then APE will use its own judgment.

Shortages

APE does not assume responsibility for any delay, damage, or loss of material while in transit. Damaged or lost material should be refused or a full description made of its condition to the carrier agent on the freight or express bill. Make any such claims immediately upon receipt of parts.

Return of Parts

If for any reason you desire to return parts to the factory or to any distributor from whom these parts were obtained, you must first secure permission to return the parts. Shipping instructions will be given along with this permission. A ten percent handling charge must be assessed against the returned shipment unless an error is made by the factory or by the distributor when filling your order.



A tag with identifying numbers for the unit.

REPLACEMENT PARTS

100 WICK DRAIN ASSEMBLY

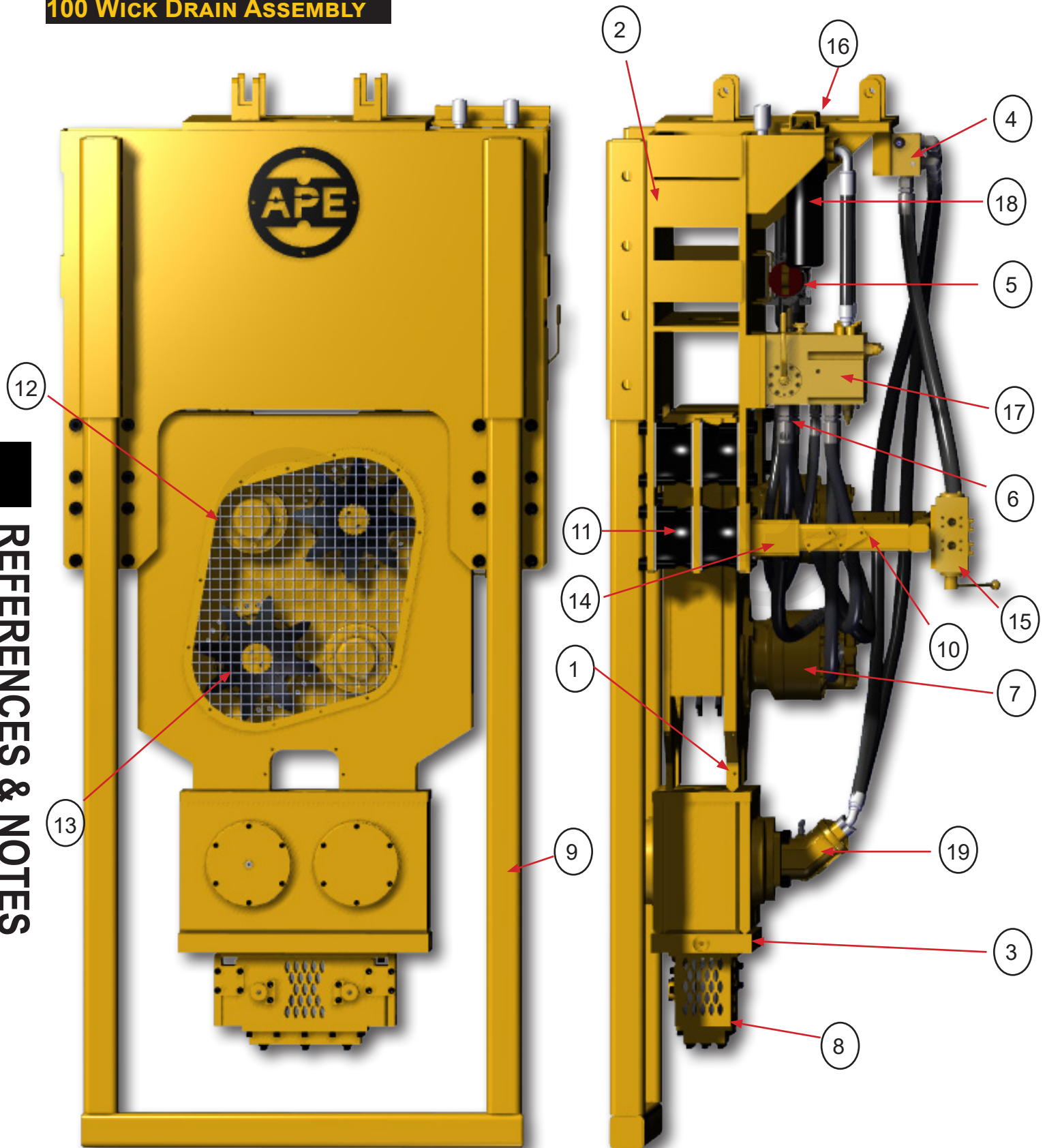

REFERENCES & NOTES



REPLACEMENT PARTS

100 WICK DRAIN ASSEMBLY BOM

ITEM NO.	PART NO.	DESCRIPTION	QTY
1	1005601	100 WICK INNER SUPP. MACHINING	1
2	1009903	100 WICK OUTER SUPP. HSING MACH EXTEND	1
3	1005599	100 GEARBOX ASM	1
4	1009541	BRAKE VALVE	1
5	1005200	ACCUMULATOR ASM	1
6	1009543	CHARGE MANIFOLD	1
7	352027	MS35 MOTOR	2
8	1002323	GUIDE ROLLER ASSEMBLY	1
9	1009904	STANDOFF LEG-EXTENDED	1
10	1001502	200 WICK SUPPORTING FRAME	1
11	100796	ELASTOMER	8
12	1002099	DIRT GUARDS ASSEMBLY	2
13	1002143	SPROCKET & HUB ASSEMBLY	2
14	352061	SUPPORT FRAME BRACKET	2
15	352021	FEROY SELECTOR VALVE	1
16	1001411	RETURN FILTER KKZ25	1
17	1001412	PRESSURE FILTER HSN60 / 13HZ10	2
18	1009541	MANIFOLD #016133	1
19	1004931	MOTOR-HYDRO LEDUC MA125	1

COMMON REPLACEMENT FILTERS

ITEM NO.	PART NO.	DESCRIPTION	QTY
1	2003562	HSN60 / 13HZ10 PRESSURE FILTER ELEMENT	2
2	100586	KKZ25 FILTER ELEMENT	1

REPLACEMENT PARTS



REPLACEMENT PARTS

100 Wick Drain Gearbox

P/N: 1005599

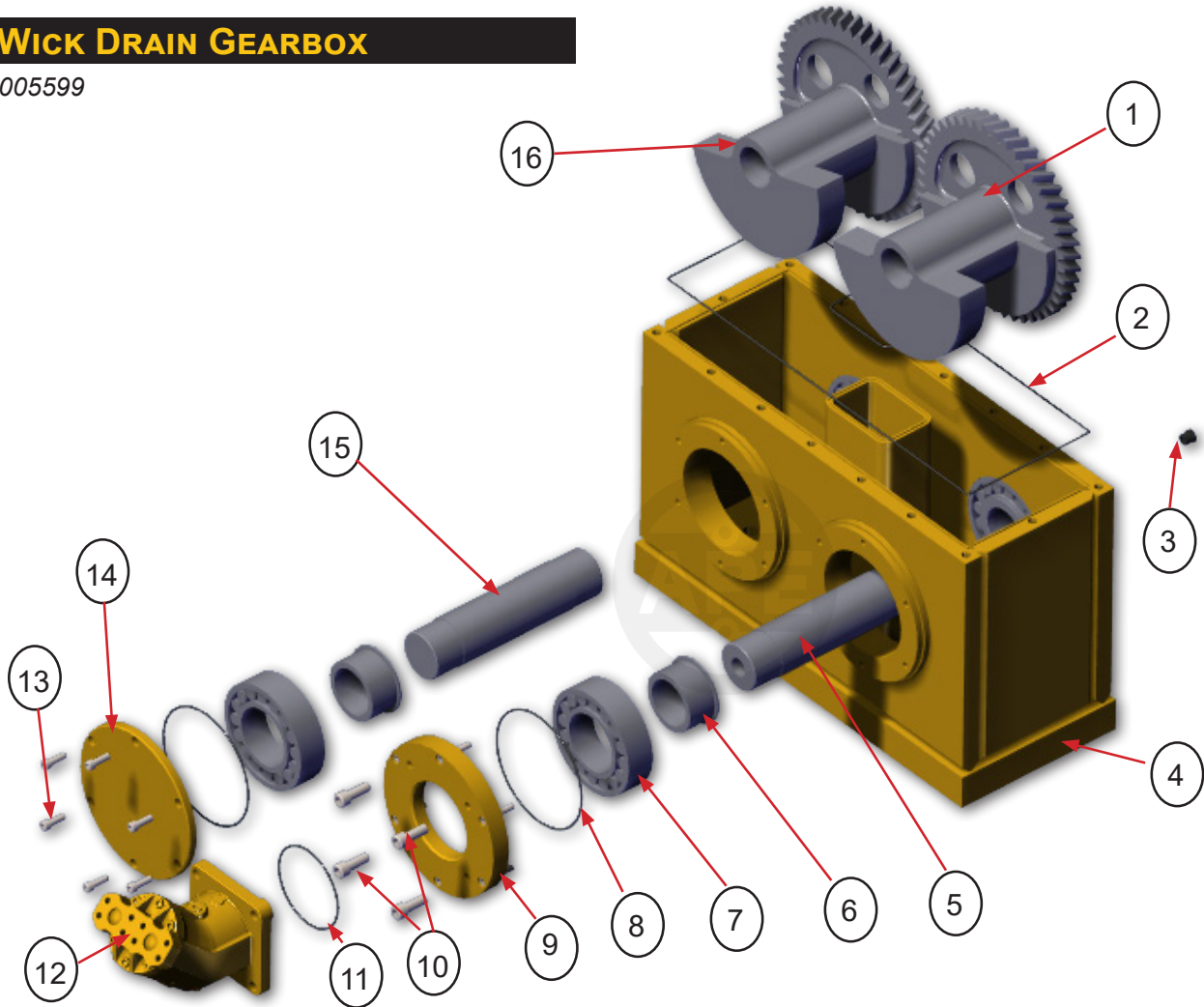

REPLACEMENT PARTS

ITEM NO.	PART NO.	DESCRIPTION	QTY
1	181007F	ECCENTRIC RIGHT	1
2	352079	O-RING CORD 0.13 C.S	1
3	123005	SIGHT GLASS	1
4	1005598	GEARBOX MACHINING	1
5	352045	DRIVE SHAFT	2
6	181005	BEARING SLEEVE	4
7	181001A	22224 ECCENTRIC BEARING	4
8	352081	2-272 O-RING	4
9	352011	BEARING COVER MOTOR MOUNT	1
10	CONTACT APE	BEARING COVER MOTOR MOUNT BOLTS SHCS	4
11	352113	2-163 O RING	1
12	1004931	MA125 PISTON MOTOR	1
13	CONTACT APE	BEARING COVER BOLTS - SHCS	24
14	181004	BEARING COVER	2
15	181003	ECCENTRIC SHAFT	1
16	181007F	ECCENTRIC LEFT	1
17	352077	ECCENTRIC BEARING COVER/SAE BREATHER PORT	1



REPLACEMENT PARTS

100 Wick A-GUIDE ROLLER ASM BOM

P/N: 1002323

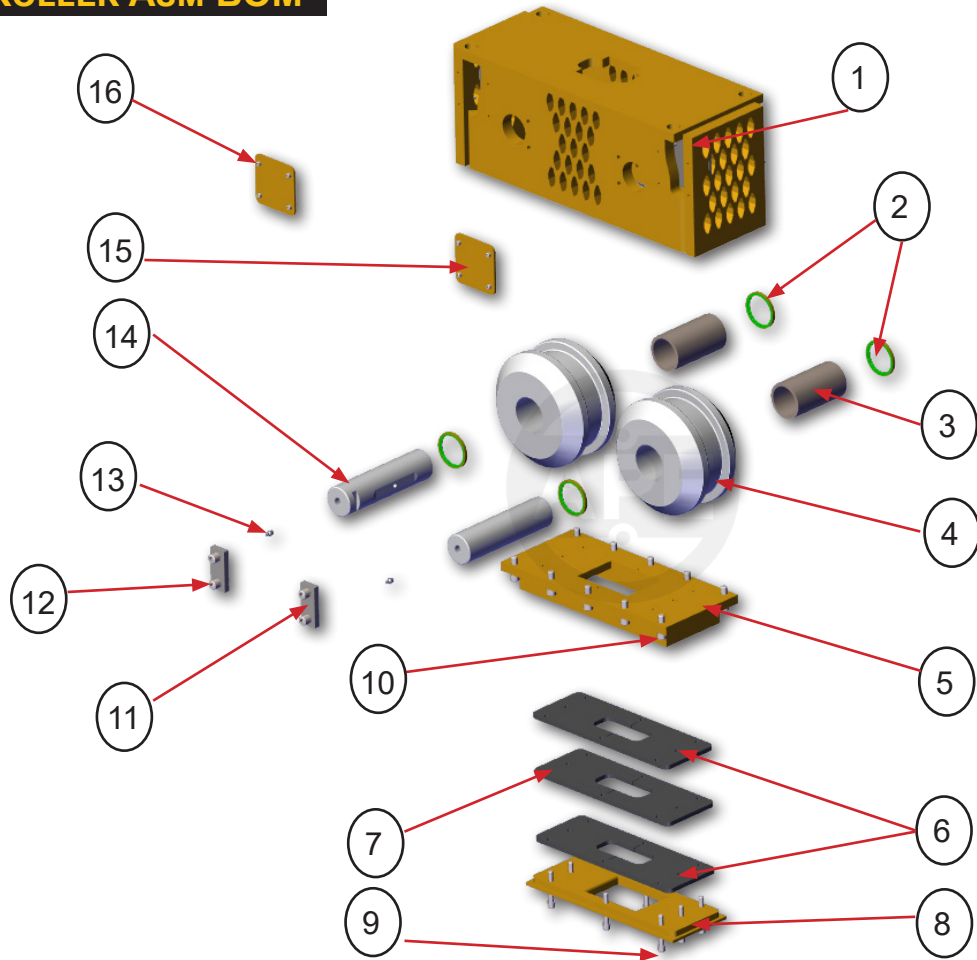

ITEM NO.	PART NO.	DESCRIPTION	QTY
1	1002292	ROLLER FRAME ASM MACHINING	1
2	1002163	WIPER SEAL ASM	4
3	1002301	BUSHING	2
4	1002300	GUIDE ROLLER	2
5	1002294	PACKING BOX MACHINING	1
6	1002298	BELTING PACKING	2
7	1002299	URETHANE PACKING	1
8	1002297	BACKING PLATE	1
9	CONTACT APE	SHCS	8
10	CONTACT APE	SHCS	10
11	352028	ROLLER PIN KEEPER PLATE	2
12	CONTACT APE	SHCS	4
13		GEASE ZERT	2
14	1002295	GUIDE ROLLER PIN	2
15	1003153	COVER PLATE	4
16		SHCS	16

REPLACEMENT PARTS



REPLACEMENT PARTS

Wick Manifold

P/N: 1003812

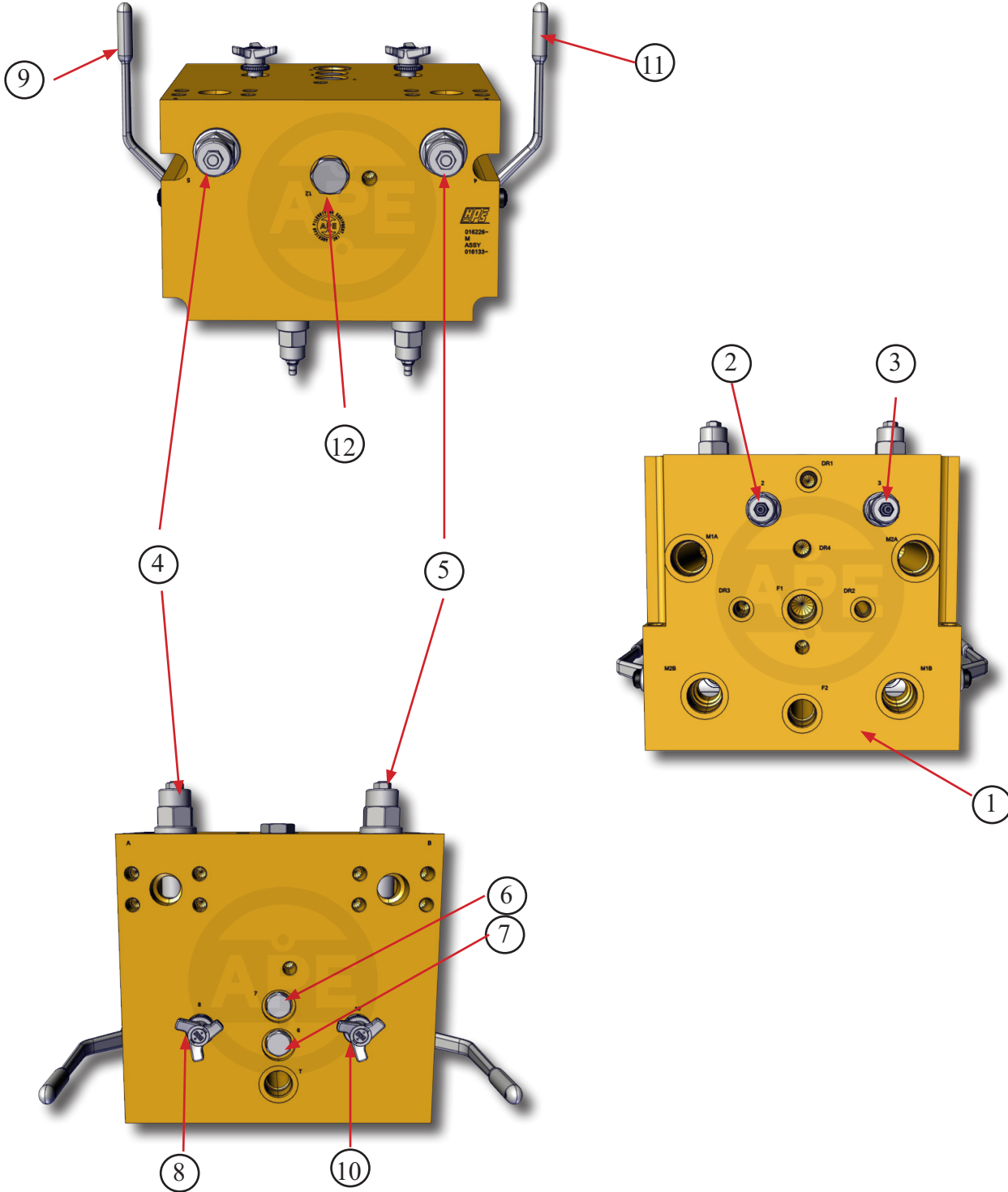

REPLACEMENT PARTS



REPLACEMENT PARTS

WICK MANIFOLD

ITEM No.	PART No.	DESCRIPTION	DESCRIPTION 2	QTY
1		DUCTILE IRON MANIFOLD BLOCK	016226	1
2	110239	RELIEF VALVE, DIRECT ACTING, T-16A	RDHALCN	1
3	110239	RELIEF VALVE, DIRECT ACTING, T-16A	RDHALCN	1
4	352117	COUNTER BALANCE VALVE 3:1, T-19A	CBIALBN	1
5	352117	COUNTER BALANCE VALVE 3:1, T-19A	CBIALBN	1
6	110233	CHECK VALVE, T-5A	CXFAXZN	1
7	110233	CHECK VALVE, T-5A	CXFAXZN	1
8	543103	FULLY ADJUSTABLE NEEDLE VALVE, T-13A	NFCCLCN	1
9	CONTACTAPE	1-1/4" BALL VALVE INTRAMANIFOLD	SV2C-1250-1111	1
10	543103	FULLY ADJUSTABLE NEEDLE VALVE, T-13A	NFCCLCN	1
11	CONTACTAPE	1-1/4" BALL VALVE INTRAMANIFOLD	SV2C-1250-1111	1
12	CONTACTAPE	CAVITY PLUG, 2W, ALL PORTS BLOCKED BUNA N	CP16-20-N	1
13	CONTACTAPE	TRIP-GRIP HANDKNOB CONTROL KIT	991034	2

BRAKE VALVE MANIFOLD

DWG #1009541

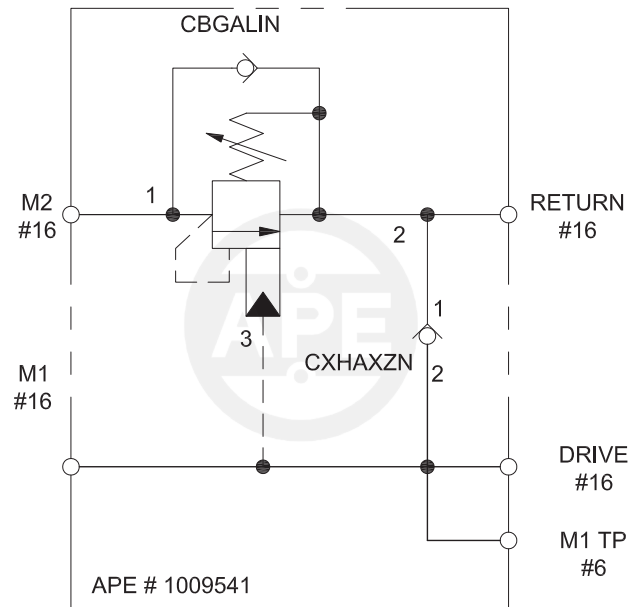
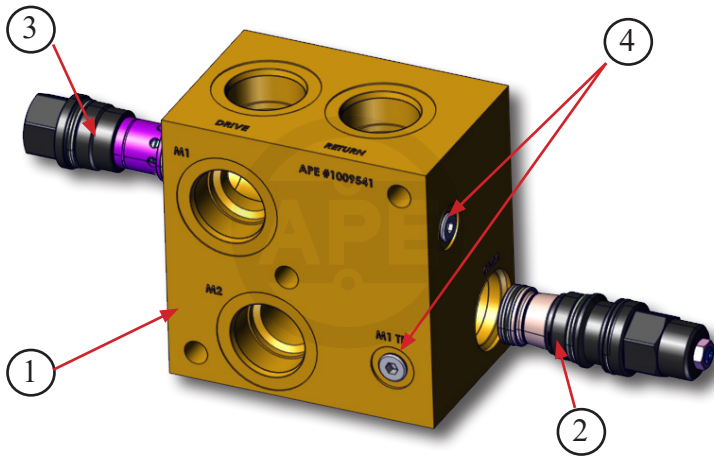

ITEM No.	PART No.	DESCRIPTION	DESCRIPTION 2	QTY
1	1009540	WICK DRAIN BRAKE VALVE MACHINED		1
2	352116	COUNTER BALANCE VALVE	CBGA-LIN	1
3	352106	CHECK VALVE	CXHA-XZN	1
4	2004448	-6 SAE PLUG	EPC006	3

REPLACEMENT PARTS

HYDRAULIC SCHEMATIC

MANDREL DRIVE:
 100 GPM = 2.8 FT/SEC
 120 GPM MAX = 3.3 FT/SEC
 4800 PSI MAX

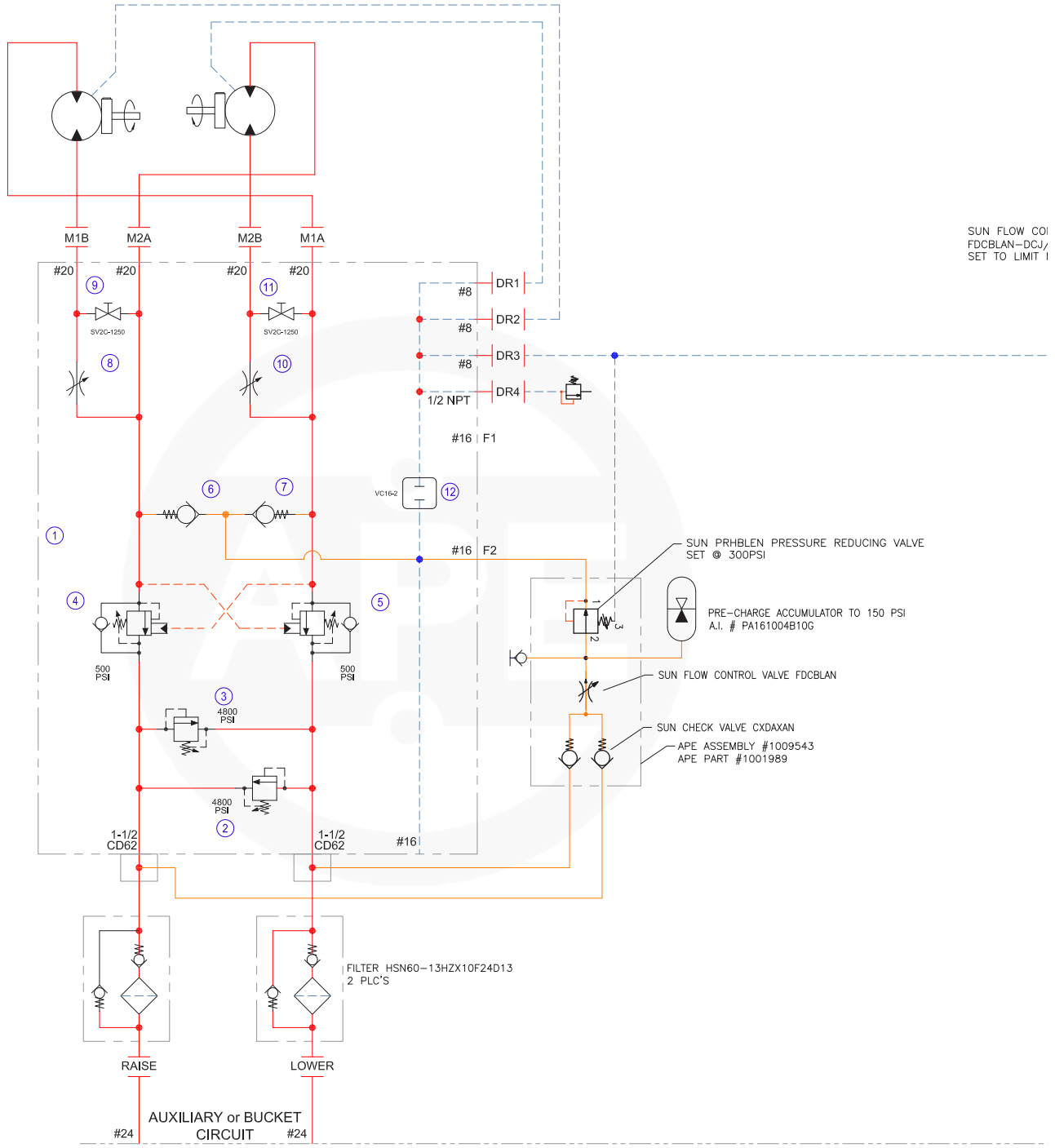

SUN FLOW COI
 FDCBLAN-DCJ/
 SET TO LIMIT 1

NOTE:
 MAX PRESSURES MUST BE SET AT THE EXCAVATOR.
 FAILURE TO DO SO WILL CAUSE THE SYSTEM TO OVERHEAT.

THE RELIEF VALVES IN MANDREL DRIVE MANIFOLD ARE FOR
 OVER PRESSURE PROTECTION ONLY, AND ARE NOT INTENDED
 TO BE USED TO REGULATE PRESSURE.

CAS
 RES
 DO

HYDRAULIC SCHEMATIC

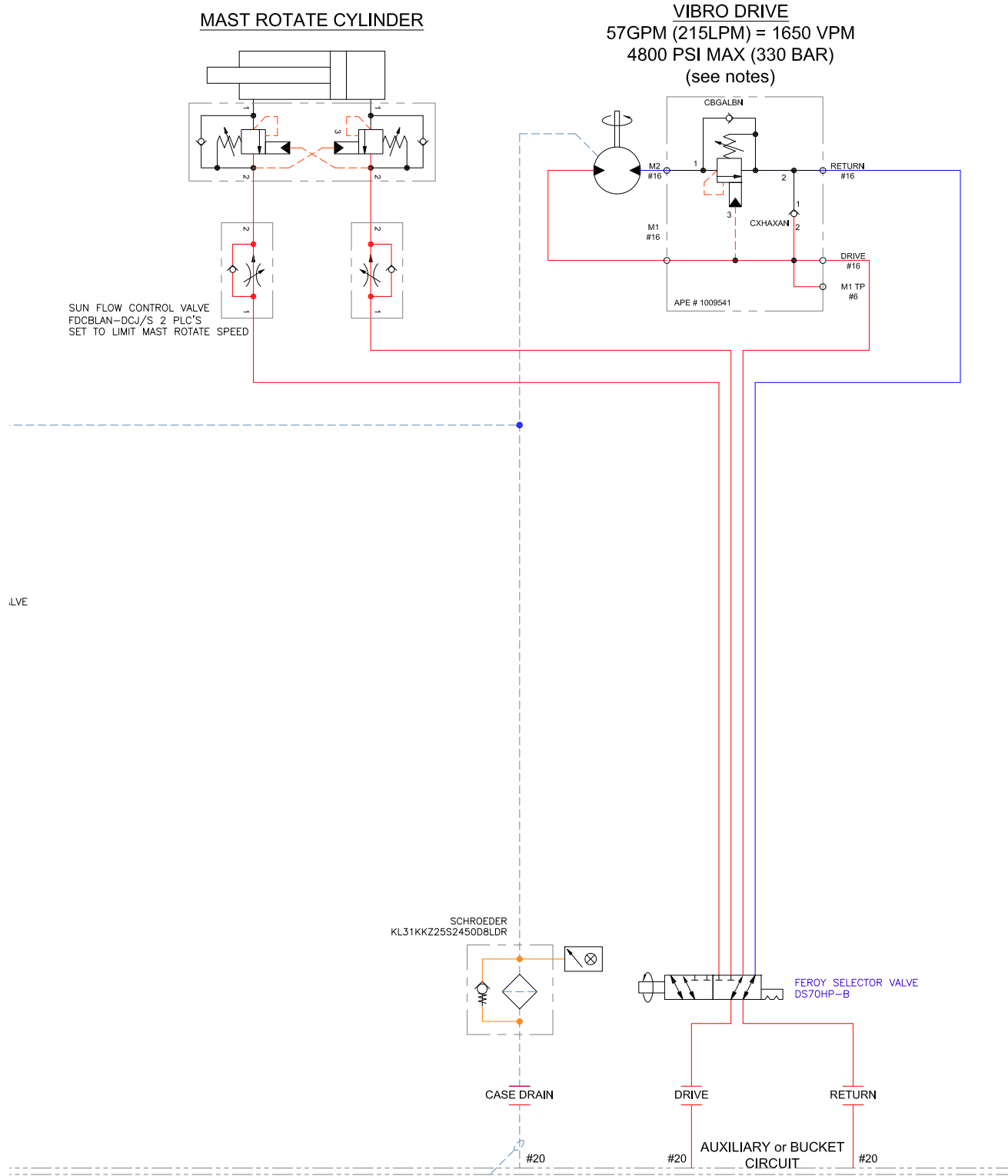

CASE DRAIN LINE MUST RETURN TO THE RESERVOIR UNRESTRICTED, DO NOT COMBINE WITH OTHER RETURN LINES

FLOW TO THE VIBRATORY HAMMER SHOULD BE LIMITED TO 57GPM (215LPM) AT THE EXCAVATOR

REPLACEMENT PARTS

REFERENCE / NOTES

DS70HP-B

2-POSITION 6-WAY SELECTOR
 CAPACITY 70 GPM
 MAX. PRESSURE 6000 PSI
 CONNECTIONS SAE 1.25 CODE 62
 WEIGHT 54 LBS.

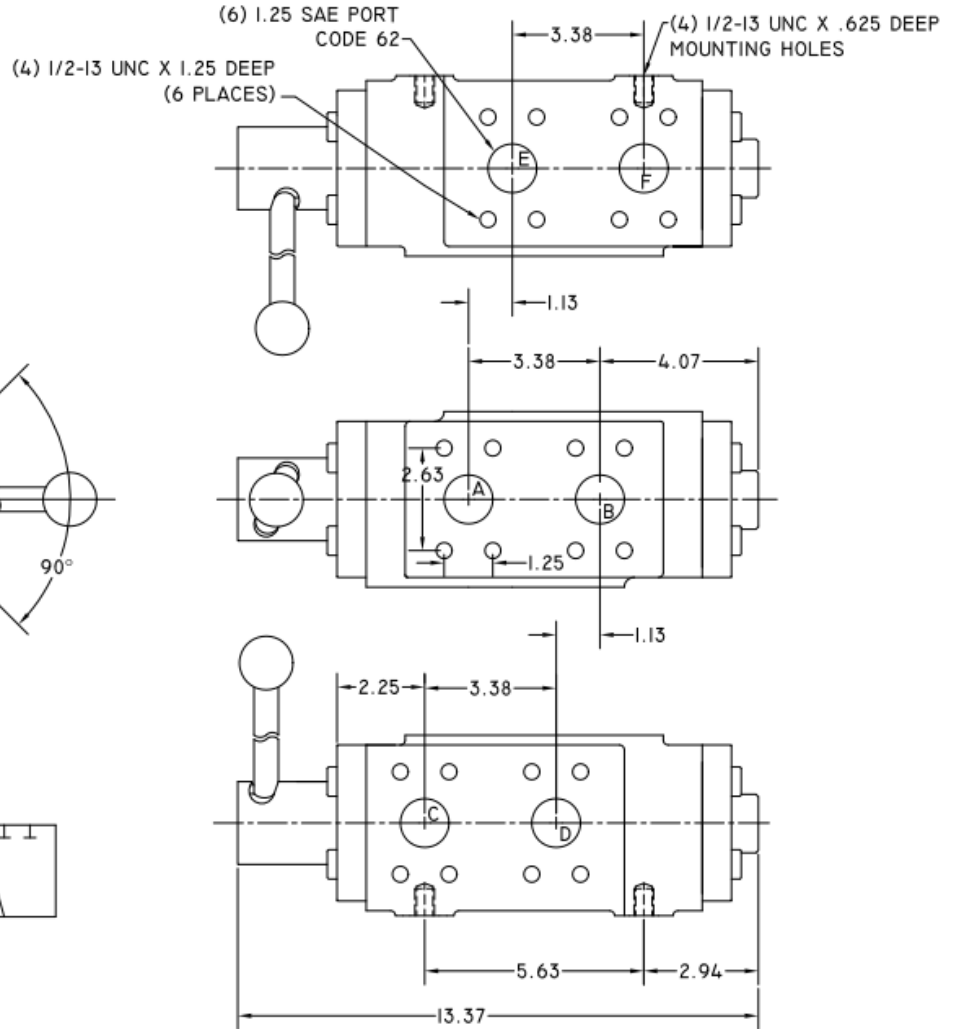
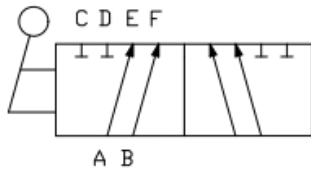
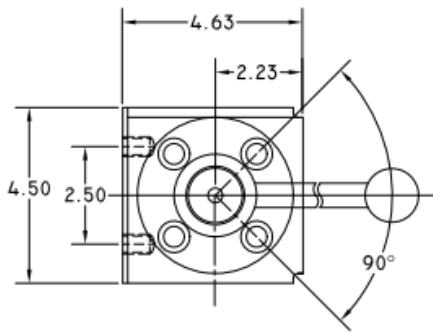

REFERENCES & NOTES

REFERENCE / NOTES

RECOMMENDED BOLT TIGHTENING TORQUE “LUBRICATED SHCS”

Socket Head Cap Screws



When installing any APE equipment or parts apply lubricant and use APE standard **Anti-Seize** torque specs.
See Tightening Torque Spec below. Failure to follow tightening torque spec can result in under / over tightening fasteners, leading to equipment failure or personal injury.

COARSE THREADS

Nominal Screw Size	Nominal Socket Size	Tightening Torque (ft-lbs)
#10-24	5/32	6
.25-20	3/16	10
.31-18	1/4	22
.38-16	5/16	38
.44-14	3/8	61
.50-13	3/8	93
.63-11	1/2	179
.75-10	5/8	317
.88-9	3/4	511
1.00-8	3/4	767
1.25-7	7/8	1,533
1.50-6	1	2,668

FINE THREADS

Nominal Screw Size	Nominal Socket Size	Tightening Torque (ft-lbs)
#10-32	5/32	6
.25-28	3/16	12
.31-24	1/4	24
.38-24	5/16	43
.44-20	3/8	68
.50-20	3/8	105
.63-18	1/2	202
.75-16	5/8	354
.88-14	3/4	564
1.00-12	3/4	860
1.25-12	7/8	1,697
1.50-12	1	3,001

RECOMMENDED ANTI-SEIZE LUBRICANT

BENEFITS & FEATURES

- **Excellent Anti-Seize** Prevents seizing caused by galling, galvanic action, fretting, fusion, pitting, thread distortion, breakage, rust, and corrosion.
- **Water Resistant** Provides long term protection with just one application, outdoors or indoors, even in the damp areas or against salt spray. Will not wash off.
- **Wide Temperature Range** Coating withstands temperatures of -65 Degree F to 2100 Degree F. (-54 C to 1100 C)
- **Stable Coating** Will not harden or fuse to metal, cake, evaporate or separate
- **Compatible with many materials** Can be used as an anti-seize on the threads of steel, stainless steel, steel alloy, cast iron, aluminum, copper brass, and titanium parts and reduces friction and wear on plastic.
- **Environmentally Desirable** Past contains no lead compounds traditionally found in this type of product.



WARNING: USING OTHER TYPES OF ANTI-SEIZE NOT RECOMMENDED BY APE CAN LEAD TO EQUIPMENT FAILURE OR PERSONAL INJURY. WARRANTY WILL BE VOIDED AND FEES MAY APPLY.

REFERENCES & NOTES



UNDERSTANDING ISO CODES

The ISO cleanliness code is used to quantify particulate contamination levels per milliliter of fluid at 3 sizes 4µ[c], 6µ[c], and 14µ[c]. The ISO code is expressed in 3 numbers (ie 19/17/14). Each number represents a contaminant level code for the correlating particle size. The code includes all particles of the specified size and larger. It is important to note that each time a code increases the quantity range of particles is doubling.

ISO 4406 Chart		
Range Code	Particles per milliliter	
	More than	Up to/including
24	80000	160000
23	40000	80000
22	20000	40000
21	10000	20000
20	5000	10000
19	2500	5000
18	1300	2500
17	640	1300
16	320	640
15	160	320
14	80	160
13	40	80
12	20	40
11	10	20
10	5	10
9	2.5	5
8	1.3	2.5
7	0.64	1.3
6	0.32	0.64

Sample 1 (see photo 1)

Particle Size	Particles per ml*	ISO 4406 Code range	ISO Code
4µ[c]	151773	80000~160000	24
6µ[c]	38363	20000~40000	22
10µ[c]	8229		
14µ[c]	3339	2500~5000	19
21µ[c]	1048		
38µ[c]	112		

Sample 2 (see photo 2)

Particle Size	Particles per ml*	ISO 4406 Code range	ISO Code
4µ[c]	492	320 ~ 640	16
6µ[c]	149	80 ~ 160	14
10µ[c]	41		
14µ[c]	15	10 ~ 20	11
21µ[c]	5		
38µ[c]	1		

Photo 1

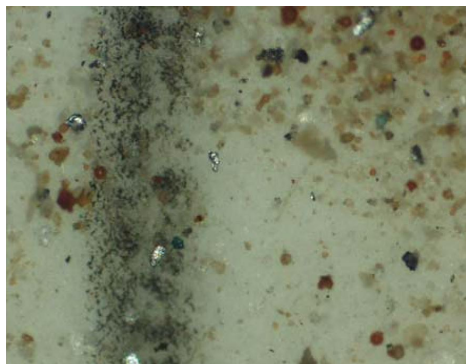

Photo 2



TARGET ISO CLEANLINESS CODES

When setting target ISO fluid cleanliness codes for hydraulic and lubrication systems it is important keep in mind the objectives to be achieved. Maximizing equipment reliability and safety, minimizing repair and replacement costs, extending useful fluid life, satisfying warranty requirements, and minimizing production down-time are attainable goals. Once a target ISO cleanliness code is set following a progression of steps to achieve that target, monitor it, and maintain it justifiable rewards will be yours.

Set the Target.

The first step in identifying a target ISO code for a system is to identify the most sensitive on an individual system, or the most sensitive component supplied by a central reservoir. If a central reservoir supplies several systems the overall cleanliness must be maintained, or the most sensitive component must be protected by filtration that cleans the fluid to the target before reaching that component.

Other Considerations

Table 1 recommends conservative target ISO cleanliness codes based on a several component manufacturers guidelines and extensive field studies for standard industrial operating conditions in systems using petroleum based fluids. If a non-petroleum based fluid is used (i.e. water glycol) the target ISO code should be set one value lower for each size (4 μ[c]/6μ[c]/14μ[c]). If a combination of the following conditions exists in the system the target ISO code should also be set one value lower:

- Component is critical to safety or overall system reliability.
- Frequent cold start.
- Excessive shock or vibration.
- Other Severe operation conditions.

Recommended* Target ISO Cleanliness Codes and media selection for systems using petroleum based fluids per ISO4406:1999 for particle sizes 4μ[c] / 6μ[c] / 14μ[c]

	Pressure	Media	Pressure	Media	Pressure	Media
	< 140 bar	βx[c] = 1000	212 bar	βx[c] = 1000	> 212 bar	βx[c] = 1000
	< 2000 psi	(βx = 200)	3000 psi	(βx = 200)	> 3000 psi	(βx = 200)
Pumps						
Fixed Gear	20/18/15	22μ[c] (25 μ)	19/17/15	12μ[c] (12 μ)	-	-
Fixed Piston	19/17/14	12μ[c] (12 μ)	18/16/13	12μ[c] (12 μ)	17/15/12	7μ[c] (6 μ)
Fixed Vane	20/18/15	22μ[c] (25 μ)	19/17/14	12μ[c] (12 μ)	18/16/13	12μ[c] (12 μ)
Variable Piston	18/16/13	7μ[c] (6 μ)	17/15/13	5μ[c] (3 μ)	16/14/12	7μ[c] (6 μ)
Variable Vane	18/16/13	7μ[c] (6 μ)	17/15/12	5μ[c] (3 μ)	-	-
Valves						
Cartridge	18/16/13	12μ[c] (12 μ)	17/15/12	7μ[c] (6 μ)	17/15/12	7μ[c] (6 μ)
Check Valve	20/18/15	22μ[c] (25 μ)	20/18/15	22μ[c] (25 μ)	19/17/14	12μ[c] (12 μ)
Directional (solenoid)	20/18/15	22μ[c] (25 μ)	19/17/14	12μ[c] (12 μ)	18/16/13	12μ[c] (12 μ)
Flow Control	19/17/14	12μ[c] (12 μ)	18/16/13	12μ[c] (12 μ)	18/16/13	12μ[c] (12 μ)
Pressure Control (modulating)	19/17/14	12μ[c] (12 μ)	18/16/13	12μ[c] (12 μ)	17/15/12	7μ[c] (6 μ)
Proportional Cartridge Valve	17/15/12	7μ[c] (6 μ)	17/15/12	7μ[c] (6 μ)	16/14/11	5μ[c] (3 μ)
Proportional Directional	17/15/12	7μ[c] (6 μ)	17/15/12	7μ[c] (6 μ)	16/14/11	5μ[c] (3 μ)
Proportional Flow Control	17/15/12	7μ[c] (6 μ)	17/15/12	7μ[c] (6 μ)	16/14/11	5μ[c] (3 μ)
Proportional Pressure Control	17/15/12	7μ[c] (6 μ)	17/15/12	7μ[c] (6 μ)	16/14/11	5μ[c] (3 μ)
Servo Valve	16/14/11	7μ[c] (6 μ)	16/14/11	5μ[c] (3 μ)	15/13/10	5μ[c] (3 μ)
Bearings						
Ball Bearing	15/13/10	5μ[c] (3 μ)	-	-	-	-
Gearbox (industrial)	17/16/13	12μ[c] (12 μ)	-	-	-	-
Journal Bearing (high speed)	17/15/12	7μ[c] (6 μ)	-	-	-	-
Journal Bearing (low speed)	17/15/12	7μ[c] (6 μ)	-	-	-	-
Roller Bearing	16/14/11	7μ[c] (6 μ)	-	-	-	-
Actuators						
Cylinders	17/15/12	7μ[c] (6 μ)	16/14/11	5μ[c] (3 μ)	15/13/10	5μ[c] (3 μ)
Vane Motors	20/18/15	22μ[c] (25 μ)	19/17/14	12μ[c] (12 μ)	18/16/13	12μ[c] (12 μ)
Axial Piston Motors	19/17/14	12μ[c] (12 μ)	18/16/13	12μ[c] (12 μ)	17/15/12	7μ[c] (6 μ)
Gear Motors	20/18/14	22μ[c] (25 μ)	19/17/13	12μ[c] (12 μ)	18/16/13	12μ[c] (12 μ)
Radial Piston Motors	20/18/15	22μ[c] (25 μ)	19/17/14	12μ[c] (12 μ)	18/16/13	12μ[c] (12 μ)
Test Stands, Hydrostatic						
Test Stands	15/13/10	5μ[c] (3 μ)	15/13/10	5μ[c] (3 μ)	15/13/10	5μ[c] (3 μ)
Hydrostatic Transmissions	17/15/13	7μ[c] (6 μ)	16/14/11	5μ[c] (3 μ)	16/14/11	5μ[c] (3 μ)

*Depending upon system volume and severity of operating conditions a combination of filters with varying degrees of filtration efficiency might be required (i.e. pressure, return, and off-line filters) to achieve and maintain the desired fluid cleanliness.

Example	ISO Code	Comments
Operating Pressure	156 bar, 2200 psi	
Most Sensitive Component	Directional Solenoid	19/17/14 recommended baseline ISO Code
Fluid Type	Water Glycol	18/16/13 Adjust down one class
Operating Conditions	Remote location, repair difficult	Adjust down one class, combination
	High ingestion rate	17/15/12 of critical nature, severe conditions

All information given in this Manual is current and valid per the information available at the time of publication. (Please check the updated revision date at the bottom of each page.)

American Piledriving Equipment (APE) reserves the right to implement changes without prior notice.

Please visit www.americanpiledriving.com for the most recent version of this publication.

AMERICAN PILEDRIVING EQUIPMENT, INC.

7032 S. 196th Street

Kent, Washington 98032

Office: 253-872-0141

Toll Free: 800-248-8498

Fax: 253-872-8710